



Installation and Operation Manual



Glo-Tech™ Bypass Valve

Manual 26204 (Revision A)

IMPORTANT



This is the safety alert symbol. It is used to alert you to potential personal injury hazards. Obey all safety messages that follow this symbol to avoid possible injury or death.

DEFINITIONS

- **DANGER**—Indicates a hazardous situation which, if not avoided, will result in death or serious injury.
- **WARNING**—Indicates a hazardous situation which, if not avoided, could result in death or serious injury.
- **CAUTION**—Indicates a hazardous situation which, if not avoided, could result in minor or moderate injury.
- **NOTICE**—Indicates a hazard that could result in property damage only (including damage to the control).
- **IMPORTANT**—Designates an operating tip or maintenance suggestion.

WARNING

The engine, turbine, or other type of prime mover should be equipped with an overspeed shutdown device to protect against runaway or damage to the prime mover with possible personal injury, loss of life, or property damage.

The overspeed shutdown device must be totally independent of the prime mover control system. An overtemperature or overpressure shutdown device may also be needed for safety, as appropriate.



Read this entire manual and all other publications pertaining to the work to be performed before installing, operating, or servicing this equipment. Practice all plant and safety instructions and precautions. Failure to follow instructions can cause personal injury and/or property damage.



This publication may have been revised or updated since this copy was produced. To verify that you have the latest revision, be sure to check the Woodward website:

www.woodward.com/pubs/current.pdf

The revision level is shown at the bottom of the front cover after the publication number. The latest version of most publications is available at:

www.woodward.com/publications

If your publication is not there, please contact your customer service representative to get the latest copy.



Any unauthorized modifications to or use of this equipment outside its specified mechanical, electrical, or other operating limits may cause personal injury and/or property damage, including damage to the equipment. Any such unauthorized modifications: (i) constitute "misuse" and/or "negligence" within the meaning of the product warranty thereby excluding warranty coverage for any resulting damage, and (ii) invalidate product certifications or listings.

NOTICE

To prevent damage to a control system that uses an alternator or battery-charging device, make sure the charging device is turned off before disconnecting the battery from the system.

NOTICE

To prevent damage to electronic components caused by improper handling, read and observe the precautions in Woodward manual 82715, *Guide for Handling and Protection of Electronic Controls, Printed Circuit Boards, and Modules*.

Revisions—Text changes are indicated by a black line alongside the text.

Woodward Governor Company reserves the right to update any portion of this publication at any time. Information provided by Woodward Governor Company is believed to be correct and reliable. However, no responsibility is assumed by Woodward Governor Company unless otherwise expressly undertaken.

© Woodward 2002
All Rights Reserved

Contents

CHAPTER 1. GENERAL INFORMATION.....	1
General Description.....	1
Determining the Required Valve Flow Coefficient.....	1
Cv (Flow Coefficient)	2
CHAPTER 2. INSTALLATION.....	3
Mounting Requirements	3
CHAPTER 3. DRIVER/ACTUATOR DETAILED SPECIFICATIONS.....	5
Regulatory Compliance	5
Specifications	5
CHAPTER 4. SERVICE OPTIONS	6
Product Service Options.....	6
Woodward Factory Servicing Options.....	7
Returning Equipment for Repair.....	8
Replacement Parts	8
Engineering Services.....	9
How to Contact Woodward.....	9
Technical Assistance.....	10
DECLARATION OF INCORPORATION.....	11

Illustrations and Tables

Figure 1-1. Flow Coefficient vs. Valve Opening Angle.....	2
Figure 2-1. Glo-Tech 60 mm Bypass Valve Outline Drawing.....	4
Table 1-1. Flow Coefficient vs. Valve Angle.....	2

Chapter 1.

General Information

General Description

The Glo-Tech™ Bypass Valve (GBV) is a high temperature butterfly valve suitable for use to regulate compressor boost-pressure on turbocharged spark-ignited engines. Its high temperature rating enables the valve to be located either between the compressor outlet and the aftercooler or downstream of the aftercooler.

The valve has been designed to be positioned by a ProAct™ Digital Plus rotary actuator through an anti-backlash coupling capable of handling considerable misalignment.

The valve has been constructed using stainless steel and other high-temperature alloys to enable it to handle continuous gas temperatures of up to 230 °C. No service or maintenance is required. The valve uses a circular valve plate, which eliminates the possibility of the plate becoming jammed in the bore due to improper rigging.



This product is not designed to be used as a fuel-control device.

The GBV valve is offered with a 60 mm internal-diameter valve body.

Determining the Required Valve Flow Coefficient

The valve flow coefficient (Cv) required by the end user can be determined by using the following equation. Cv values should be calculated for the minimum and maximum flows expected on the application. Using the calculated Cv values and the graph and chart below, verify that the GBV's flow coefficients are acceptable for the application. The valve should have enough flow area at the maximum opening and also provide a minimum Cv less than required by the end user.

$$C_v := \frac{Q \cdot 0.00976}{P_1 \cdot S_g} \cdot \sqrt{\frac{(T + 460) \cdot P_1 \cdot S_g}{P_1 - P_2}}$$

Where:

Q = mass flow (PPH)

S_g = specific gravity of fluid (= 1.0 for air)

T = gas temperature (°F)

P₁ = inlet pressure (psia)

P₂ = discharge pressure (psia)

P₂ must be greater than or equal to 0.528 * P₁ (or flow becomes choked)

If P₂ is less than 0.528 * P₁, use P₂ = 0.528 * P₁

Cv (Flow Coefficient)

Valve Angle	Cv 60 mm
0	2.51
5	2.92
10	3.16
15	5.05
20	7.86
25	11.79
30	16.99
35	23.52
40	31.87
45	43.00
50	57.50
55	74.35
60	96.29
65	119.65
70	148.26

Table 1-1. Flow Coefficient vs. Valve Angle

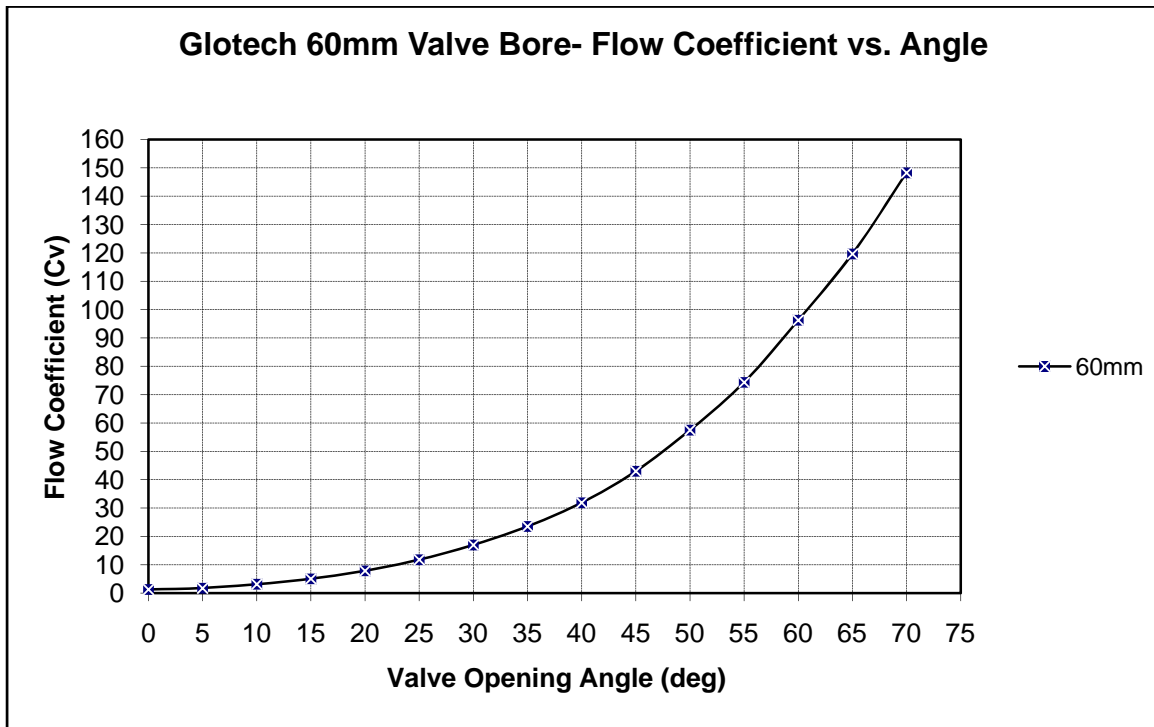

Figure 1-1. Flow Coefficient vs. Valve Opening Angle

Chapter 2. Installation

WARNING

This device is not intended to be used as a fuel delivery component. This device is a wastegate control valve only.

CAUTION

Due to typical noise levels in engine environments, hearing protection should be worn when working on or around the Glo-Tech™ valve.

CAUTION

The surface of this product can become hot enough or cold enough to be a hazard. Use protective gear for product handling in these circumstances. Temperature ratings are included in the specification section of this manual.

NOTICE

Do not drop or damage the device during installation.

Be sure that mounting surfaces are stable throughout the device life cycle.

Do not place any foreign objects in any openings in the device's exterior.

Mounting Requirements

The attitude of the valve/actuator assembly is unimportant. For thermal and vibration limitations, and mounting recommendations with the ProAct™ actuator, refer to Woodward manual 26112, *ProAct Digital Plus*.

Use V-band clamps (Woodward part number 9040-213) to make the connections between the bypass lines and the valve. Woodward recommends incorporating a pilot feature into the end user's piping to center the valve prior to tightening the V-band clamps. The valve has been designed with this in mind and has counterbores on both ends for this purpose. See Figure 2-1 (outline drawing) for counterbore dimensions.

In order to achieve minimal external leakage as reflected in the specifications section, the end user should incorporate O-ring seals into the mating flanges at the valve/flange interface. The recommended seal is an 0.070-inch (1.78 mm) cross section O-ring (such as Parker 2-042).

Since the valve has a circular butterfly plate and no internal stops, the ProAct actuator's minimum and maximum travel stops will be used. To clock the valve to the actuator with the piping installed, a special rig tool is required. This tool (Woodward part number 8996-2010) enables the valve to be positioned in the closed position without access to the valve plate. For detailed mounting/rigging instructions to couple the valve and actuator, see Figure 2-1.

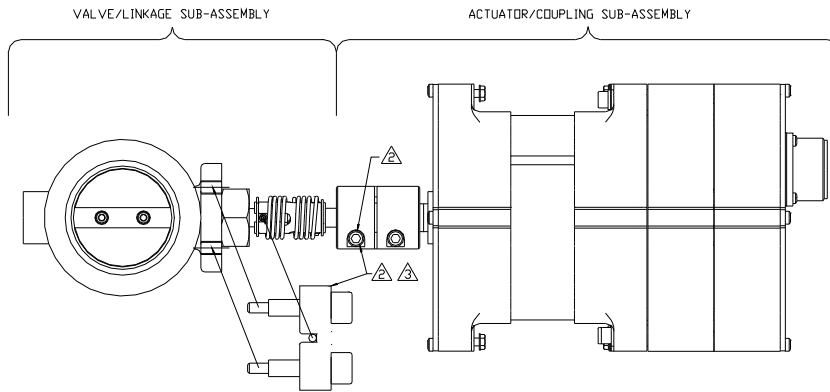
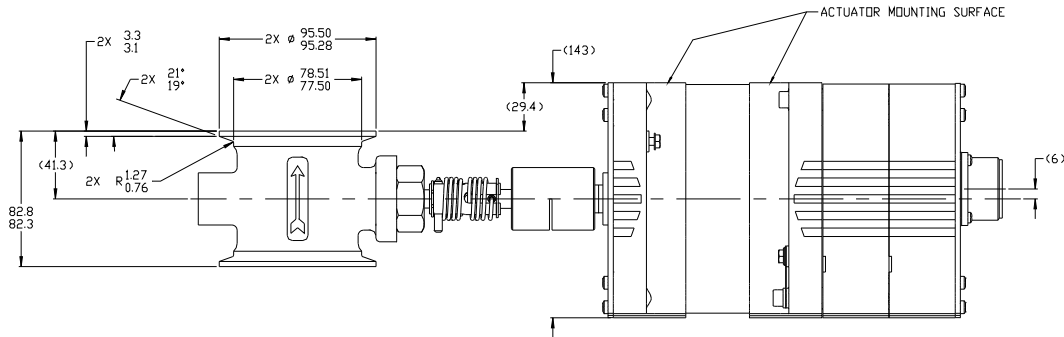
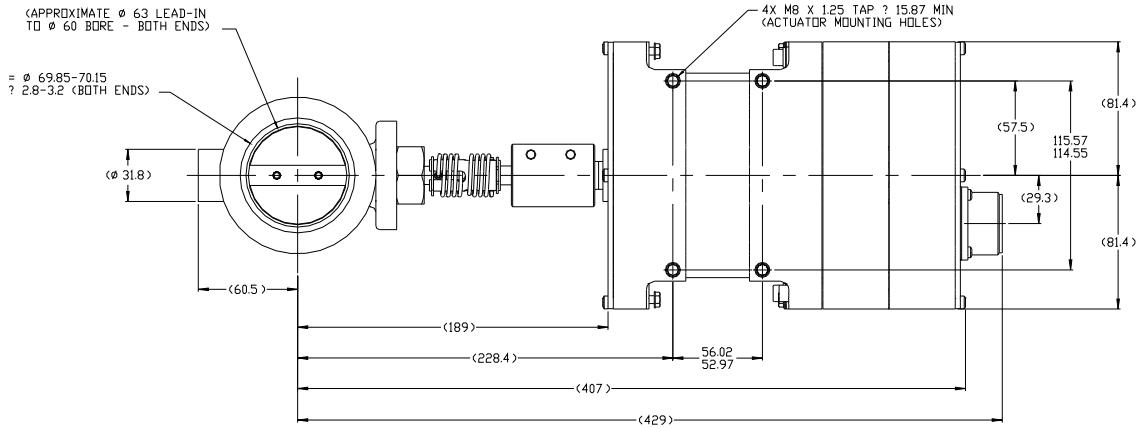

RIGGING TOOL:
ENGAGES ROLL PIN IN VALVE SHAFT AND TWO
NEAREST TAPPED HOLES IN VALVE FLANGE.

262-002
02-8-29

ASSEMBLY SEQUENCE:

1. MOUNT ACTUATOR/COUPLING SUB-ASSEMBLY. IF DESIRED, COUPLING MAY BE RE-POSITIONED FOR EASIER ACCESS TO COUPLING SCREWS BY LOOSENING CLAMP SCREW NEAREST THE ACTUATOR, REMOVING AND REPOSITIONING COUPLING (PUSH COUPLING ONTO SHAFT UNTIL IT CONTACTS SHAFT SHOULDER), THEN RE-TIGHTENING COUPLING SCREW TO 19 Nm (14 LB FT).

⚠ ENGAGE SMOOTH SHAFT OF VALVE/LINKAGE SUB-ASSEMBLY INTO COUPLING (DO NOT TIGHTEN SECOND COUPLING SCREW YET) AND MOUNT VALVE IN PIPING NOTING PROPER ORIENTATION OF FLOW DIRECTION ARROW ON SIDE OF VALVE HOUSING.

⚠ USE RIGGING TOOL TO HOLD VALVE THROTTLE PLATE IN THE CLOSED POSITION (LONG END OF ROLL PIN WHICH ENGAGES RIGGING TOOL SHOULD BE POINTING IN THE OPPOSITE DIRECTION AS THE FLOW ARROW ON THE VALVE HOUSING). MANUALLY ROTATE ACTUATOR SHAFT TO MINIMUM (LOOKING AT ACTUATOR SHAFT, ROTATE COUPLING CLOCKWISE UNTIL THE INTERNAL ACTUATOR STOP IS CONTACTED). TIGHTEN SECOND COUPLING SCREW TO 19 Nm (14 LB FT).

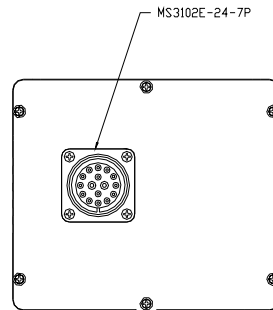

Figure 2-1. Glo-Tech 60 mm Bypass Valve Outline Drawing

Chapter 3.

Driver/Actuator Detailed Specifications

Regulatory Compliance

Machinery Directive	Compliance as a component with 98/37/EC COUNCIL DIRECTIVE of 23 July 1998 on the approximation of the laws of the Member States relating to machinery.
Pressure Equipment Directive	Exempt per Article 1-3.10

Specifications

Gas Inlet Temperature	-40 to +230 °C (-40 to +446 °F)
Ambient Temperature	-30 to +85 °C (-22 to +185 °F)
Humidity Qualification Test Level	Tested at 25 to 60 °C, 85 to 95% RH, 5 cycles at 24 hours/cycle (test derived from DNV C.N2.4, Damp Heat)
Vibration Qualification Test Level	0.1 G ² /Hz Random, 10–2000 Hz, 12.8 Grms, 3 hours/axis (test derived from MS202F, Method 214A, Test Condition D)
Shock Qualification Test Level	40 G, 11 ms sawtooth pulse (test derived from US MIL-STD810C, M516.2,P1)
Valve Mass/Weight	1.6 kg (3.6 lbs)
Maximum Inlet Pressure	10 bar (145 psig)
Maximum Pressure Differential	3.8 bar (55.1 psid)
Maximum External Leakage	< 3 SCCM @ 40.4 psid
Maximum Misalignment between valve and actuator	2 degrees maximum in any direction between valve and actuator axes

Chapter 4. Service Options

Product Service Options

If you are experiencing problems with the installation, or unsatisfactory performance of a Woodward product, the following options are available:

- Consult the troubleshooting guide in the manual.
- Contact the manufacturer or packager of your system.
- Contact the Woodward Full Service Distributor serving your area.
- Contact Woodward technical assistance (see “How to Contact Woodward” later in this chapter) and discuss your problem. In many cases, your problem can be resolved over the phone. If not, you can select which course of action to pursue based on the available services listed in this chapter.

OEM and Packager Support: Many Woodward controls and control devices are installed into the equipment system and programmed by an Original Equipment Manufacturer (OEM) or Equipment Packager at their factory. In some cases, the programming is password-protected by the OEM or packager, and they are the best source for product service and support. Warranty service for Woodward products shipped with an equipment system should also be handled through the OEM or Packager. Please review your equipment system documentation for details.

Woodward Business Partner Support: Woodward works with and supports a global network of independent business partners whose mission is to serve the users of Woodward controls, as described here:

- A **Full Service Distributor** has the primary responsibility for sales, service, system integration solutions, technical desk support, and aftermarket marketing of standard Woodward products within a specific geographic area and market segment.
- An **Authorized Independent Service Facility (AISF)** provides authorized service that includes repairs, repair parts, and warranty service on Woodward's behalf. Service (not new unit sales) is an AISF's primary mission.
- A **Recognized Engine Retrofitter (RER)** is an independent company that does retrofits and upgrades on reciprocating gas engines and dual-fuel conversions, and can provide the full line of Woodward systems and components for the retrofits and overhauls, emission compliance upgrades, long term service contracts, emergency repairs, etc.
- A **Recognized Turbine Retrofitter (RTR)** is an independent company that does both steam and gas turbine control retrofits and upgrades globally, and can provide the full line of Woodward systems and components for the retrofits and overhauls, long term service contracts, emergency repairs, etc.

A current list of Woodward Business Partners is available at www.woodward.com/support.

Woodward Factory Servicing Options

The following factory options for servicing Woodward products are available through your local Full-Service Distributor or the OEM or Packager of the equipment system, based on the standard Woodward Product and Service Warranty (5-01-1205) that is in effect at the time the product is originally shipped from Woodward or a service is performed:

- Replacement/Exchange (24-hour service)
- Flat Rate Repair
- Flat Rate Remanufacture

Replacement/Exchange: Replacement/Exchange is a premium program designed for the user who is in need of immediate service. It allows you to request and receive a like-new replacement unit in minimum time (usually within 24 hours of the request), providing a suitable unit is available at the time of the request, thereby minimizing costly downtime. This is a flat-rate program and includes the full standard Woodward product warranty (Woodward Product and Service Warranty 5-01-1205).

This option allows you to call your Full-Service Distributor in the event of an unexpected outage, or in advance of a scheduled outage, to request a replacement control unit. If the unit is available at the time of the call, it can usually be shipped out within 24 hours. You replace your field control unit with the like-new replacement and return the field unit to the Full-Service Distributor.

Charges for the Replacement/Exchange service are based on a flat rate plus shipping expenses. You are invoiced the flat rate replacement/exchange charge plus a core charge at the time the replacement unit is shipped. If the core (field unit) is returned within 60 days, a credit for the core charge will be issued.

Flat Rate Repair: Flat Rate Repair is available for the majority of standard products in the field. This program offers you repair service for your products with the advantage of knowing in advance what the cost will be. All repair work carries the standard Woodward service warranty (Woodward Product and Service Warranty 5-01-1205) on replaced parts and labor.

Flat Rate Remanufacture: Flat Rate Remanufacture is very similar to the Flat Rate Repair option with the exception that the unit will be returned to you in “like-new” condition and carry with it the full standard Woodward product warranty (Woodward Product and Service Warranty 5-01-1205). This option is applicable to mechanical products only.

Returning Equipment for Repair

If a control (or any part of an electronic control) is to be returned for repair, please contact your Full-Service Distributor in advance to obtain Return Authorization and shipping instructions.

When shipping the item(s), attach a tag with the following information:

- return number;
- name and location where the control is installed;
- name and phone number of contact person;
- complete Woodward part number(s) and serial number(s);
- description of the problem;
- instructions describing the desired type of repair.

Packing a Control

Use the following materials when returning a complete control:

- protective caps on any connectors;
- antistatic protective bags on all electronic modules;
- packing materials that will not damage the surface of the unit;
- at least 100 mm (4 inches) of tightly packed, industry-approved packing material;
- a packing carton with double walls;
- a strong tape around the outside of the carton for increased strength.

NOTICE

To prevent damage to electronic components caused by improper handling, read and observe the precautions in Woodward manual 82715, *Guide for Handling and Protection of Electronic Controls, Printed Circuit Boards, and Modules*.

Replacement Parts

When ordering replacement parts for controls, include the following information:

- the part number(s) (XXXX-XXXX) that is on the enclosure nameplate;
- the unit serial number, which is also on the nameplate.

Engineering Services

Woodward offers various Engineering Services for our products. For these services, you can contact us by telephone, by email, or through the Woodward website.

- Technical Support
- Product Training
- Field Service

Technical Support is available from your equipment system supplier, your local Full-Service Distributor, or from many of Woodward's worldwide locations, depending upon the product and application. This service can assist you with technical questions or problem solving during the normal business hours of the Woodward location you contact. Emergency assistance is also available during non-business hours by phoning Woodward and stating the urgency of your problem.

Product Training is available as standard classes at many of our worldwide locations. We also offer customized classes, which can be tailored to your needs and can be held at one of our locations or at your site. This training, conducted by experienced personnel, will assure that you will be able to maintain system reliability and availability.

Field Service engineering on-site support is available, depending on the product and location, from many of our worldwide locations or from one of our Full-Service Distributors. The field engineers are experienced both on Woodward products as well as on much of the non-Woodward equipment with which our products interface.

For information on these services, please contact us via telephone, email us, or use our website and reference www.woodward.com/support, and then **Customer Support**.

How to Contact Woodward

For assistance, call one of the following Woodward facilities to obtain the address and phone number of the facility nearest your location where you will be able to get information and service.

Electrical Power Systems		Engine Systems		Turbine Systems	
Facility	Phone Number	Facility	Phone Number	Facility	Phone Number
Australia	+61 (2) 9758 2322	Australia	+61 (2) 9758 2322	Australia	+61 (2) 9758 2322
Brazil	+55 (19) 3708 4800	Brazil	+55 (19) 3708 4800	Brazil	+55 (19) 3708 4800
China	+86 (512) 6762 6727	China	+86 (512) 6762 6727	China	+86 (512) 6762 6727
Germany:		Germany:			
Kempen	+49 (0) 21 52 14 51	Stuttgart	+49 (711) 78954-0		
Stuttgart	+49 (711) 78954-0	India	+91 (129) 4097100	India	+91 (129) 4097100
India	+91 (129) 4097100	Japan	+81 (43) 213-2191	Japan	+81 (43) 213-2191
Japan	+81 (43) 213-2191	Korea	+82 (51) 636-7080	Korea	+82 (51) 636-7080
Korea	+82 (51) 636-7080	The Netherlands	+31 (23) 5661111	The Netherlands	+31 (23) 5661111
Poland	+48 12 618 92 00				
United States	+1 (970) 482-5811	United States	+1 (970) 482-5811	United States	+1 (970) 482-5811

You can also contact the Woodward Customer Service Department or consult our worldwide directory on Woodward's website (www.woodward.com/support) for the name of your nearest Woodward distributor or service facility.

For the most current product support and contact information, please refer to the latest version of publication **51337** at www.woodward.com/publications.

Technical Assistance

If you need to telephone for technical assistance, you will need to provide the following information. Please write it down here before phoning:

General

Your Name _____
 Site Location _____
 Phone Number _____
 Fax Number _____

Prime Mover Information

Engine/Turbine Model Number _____
 Manufacturer _____
 Number of Cylinders (if applicable) _____
 Type of Fuel (gas, gaseous, steam, etc) _____
 Rating _____
 Application _____

Control/Governor Information

Please list all Woodward governors, actuators, and electronic controls in your system:

Woodward Part Number and Revision Letter

Control Description or Governor Type

Serial Number

Woodward Part Number and Revision Letter

Control Description or Governor Type

Serial Number

Woodward Part Number and Revision Letter

Control Description or Governor Type

Serial Number

If you have an electronic or programmable control, please have the adjustment setting positions or the menu settings written down and with you at the time of the call.

Declaration of Incorporation

Woodward Governor Company
1000 E. Drake Road
Fort Collins, Colorado 80525
United States of America

Product: Glotech Bypass Valve
Part Number: 6945-1018

The undersigned hereby declares, on behalf of Woodward Governor Company of Loveland and Fort Collins, Colorado, that the above-referenced product is in conformity with the following EU Directives as they apply to a component:

98/37/EC (Machinery)

This product is intended to be put into service only upon incorporation into an apparatus/system that itself will meet the requirements of the above Directives and bears the CE mark.

Manufacturer

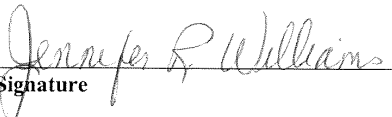
Signature

Jennifer R. Williams

Full Name

Engineering Project/Process Manager

Position

WGC, Fort Collins, CO, USA

Location

8-16-02

Date

We appreciate your comments about the content of our publications.

Send comments to: icinfo@woodward.com

Please reference publication **26204A**.



PO Box 1519, Fort Collins CO 80522-1519, USA
1000 East Drake Road, Fort Collins CO 80525, USA
Phone +1 (970) 482-5811 • Fax +1 (970) 498-3058

Email and Website—www.woodward.com

**Woodward has company-owned plants, subsidiaries, and branches,
as well as authorized distributors and other authorized service and sales facilities throughout the world.**

Complete address / phone / fax / email information for all locations is available on our website.